

Doppelte Silberspur (Redundanz)
Double silver track (redundancy)

GMP 1,0 • GMPZ 1,0
HÜBNER Analog-Tacho

LongLife-DC-Tachodynamo / *Tachogenerator*

Doppel-Tacho / *Twin Tachogenerator*

GMP 1,0 • GMPZ 1,0

**Drehzahl-Sensor
(DC-Tacho/Doppel-DC-Tacho) für den Einsatz
in der Meß-, Regel- und Antriebstechnik
mit hohen Anforderungen an die Robustheit.**

**Rotary speed sensor
(dc tachogenerator/twin dc tachogenerator)
for drive, control and measurement technology
in all industries which demand high ruggedness.**

HÜBNER-LongLife®-DC-Tachodynamos

mit der patentierten Silberspur haben neue Maßstäbe in der Antriebstechnik gesetzt:

- **Drehzahl-Spannungs-Kennlinie $U_0(n)$** mit hoher Genauigkeit, auch unter erschwerten Betriebsbedingungen
- **Sehr kleine Zeitkonstante τ_A** der Tachospannung
- **Wartungsfrei** während der Kugellager-Lebensdauer ($\geq 10^9$ Umdrehungen)
- **Garantie 2 Jahre** im Rahmen der Bedingungen des Zentralverbandes der Elektroindustrie (ZVEI), Zertifizierung nach **ISO 9001**
- Fordern Sie unsere ausführliche Druckschrift "Informationen für den Anwender - **12 Argumente für HÜBNER LongLife®-Tachos**" an oder rufen Sie sie auf unserer Website auf.

HÜBNER LongLife® dc tachogenerators

with their patented silver track have set new standards in drive technology:

- **Speed to voltage characteristic $U_0(n)$** with high precision, even under harsh operating conditions
- **Signal generating in real time with very low time constant τ_A**
- **Maintenance free** during the life time of the ball bearings ($\geq 10^9$ revolutions)
- **Guarantee 2 years** within the conditions of the Association of the German Electrical Industry (ZVEI), **ISO 9001** certified
- We have available our detailed brochure "Information for the user - **12 Arguments for HÜBNER LongLife®-Tachos**" or you can find it on our website.

Besondere Eigenschaften:

- **Doppelte Silberspur** (Redundanz)
- Robuste **Konstruktion** für größere Antriebsmaschinen
- **Temperaturkompensation** serienmäßig
- **Seeluft- und Tropenschutz** (Option)
- **2. Wellenende** (Option)
- Zwei **getrennte** Tachospnungen: **GMPZ 1,0**
- Mit angebautem **Digital-Tacho** (Drehimpulsgeber) und / oder **Drehzahlschalter** lieferbar

Special features:

- **Double silver track** (redundancy)
- **Rugged construction** for larger drives
- **Temperature compensation** as standard
- **Marine air protected and tropicalized** optional
- **2nd shaft end** optional
- Two **separate** tacho voltages: **GMPZ 1,0**
- Available with built-ond **Digital-Tacho** (incremental encoder) and / or **overspeed switch**

Typ Type	Leerlaufspannung No-load voltage	Drehzahlbereich [min ⁻¹] Speed range [rpm]			Max. Drehzahl max. Speed	Anker-Widerstand Armature Resistance	Anker-Induktivität Armature Inductance
	U_0 [mV/min ⁻¹]	R_{Load} [k Ω]	R_{Load} [k Ω]	R_{Load} [k Ω]	n_{max} [min ⁻¹]	R_A (20 °C) [Ω]	L_A [mH]
GMP 1,0 LT - 10	40	$\geq 0,15$	$\geq 0,5$	≥ 2	6 000	12	90
GMP 1,0 LT - 7	65	$\geq 0,4$	$\geq 1,3$	≥ 5	6 000	33	225
GMP 1,0 LT - 4	100	≥ 1	≥ 3	≥ 12	6 000	81	550
GMP 1,0 LT - 1	175	≥ 3	≥ 10	≥ 12	3 400	275	1650
Doppel-Tacho mit zwei getrennten Tachospnungen / Twin tachogenerator with two separate tacho voltages							
GMPZ 1,0 LT - 10	40	$\geq 0,15$	$\geq 0,5$	≥ 2	6 000	9	40
GMPZ 1,0 LT - 7	65	$\geq 0,4$	$\geq 1,3$	≥ 5	6 000	23	110
GMPZ 1,0 LT - 4	100	≥ 1	≥ 3	≥ 12	6 000	56	270
GMPZ 1,0 LT - 1	175	≥ 3	≥ 10	≥ 12	3 400	175	745
Die Daten gelten für jeden der beiden Tachoaussgänge / The data refer to each of the two tacho outputs							
* früher formely	GMP 1,0 + GMPZ 1,0						

Leistung <i>Power</i>	$P_{max.}$	GMP 1,0 30 W GMPZ 1,0 2 x 30 W	$n \geq 3\,000 \text{ min}^{-1} / \text{rpm}$
Kalibriertoleranz <i>Calibration tolerance</i>		$\pm 3 \%$	
Linearitätstoleranz <i>Linearity tolerance</i>		$\leq 0,5 \%$	
Reversiertoleranz <i>Reversing tolerance</i>		$\leq 0,1 \%$	
Überlagerte Welligkeit <i>Superimposed ripple</i>	$\tau_{RC} = 1 \text{ ms}$	$\leq 1,0 \%$ Spitze-Spitze <i>peak-peak</i>	$\leq 0,5 \%$ effektiv <i>rms</i>
Temperaturkoeffizient im Leerlauf <i>Temperature coefficient at no-load</i>		$\pm 0,005 \%$ / K	
Ankerkreis-Zeitkonstante <i>Time constant of rotor</i>	τ_A	GMP 1,0 $\leq 0,55 \mu\text{s}$ GMPZ 1,0 $\leq 0,27 \mu\text{s}$	
Leerlauf-Antriebsdrehmoment <i>Driving torque at no-load</i>		GMP 1,0 2 Ncm GMPZ 1,0 3,3 Ncm	
Trägheitsmoment <i>Moment of inertia</i>		GMP 1,0 4,5 kgcm ² GMPZ 1,0 8,5 kgcm ²	
Belastbarkeit der Welle <i>Load on shaft</i>	max.	axial 80 N	radial 100 N
Schwingungsfestigkeit <i>Vibration proof</i>		$\leq 10 \text{ g} \approx 100 \text{ m/s}^2$	(10 Hz ... 2 kHz) DIN IEC 68-2-6
Schockfestigkeit <i>Shock proof</i>		$\leq 100 \text{ g} \approx 1\,000 \text{ m/s}^2$	(6 ms) DIN IEC 68-2-27
Temperaturbereich <i>Temperature range</i>	T	$-30 \text{ }^\circ\text{C} \dots +130 \text{ }^\circ\text{C}$	Isolationsklasse <i>Insulation class</i> B
Schutzart <i>Protection</i>		IP 55	IEC 34-5
Klimaschutz <i>Climatic protection</i>		DIN IEC 68, 2-3, Ca	
Gewicht <i>Weight</i>		GMP 1,0 4,5 kg GMPZ 1,0 7,0 kg	

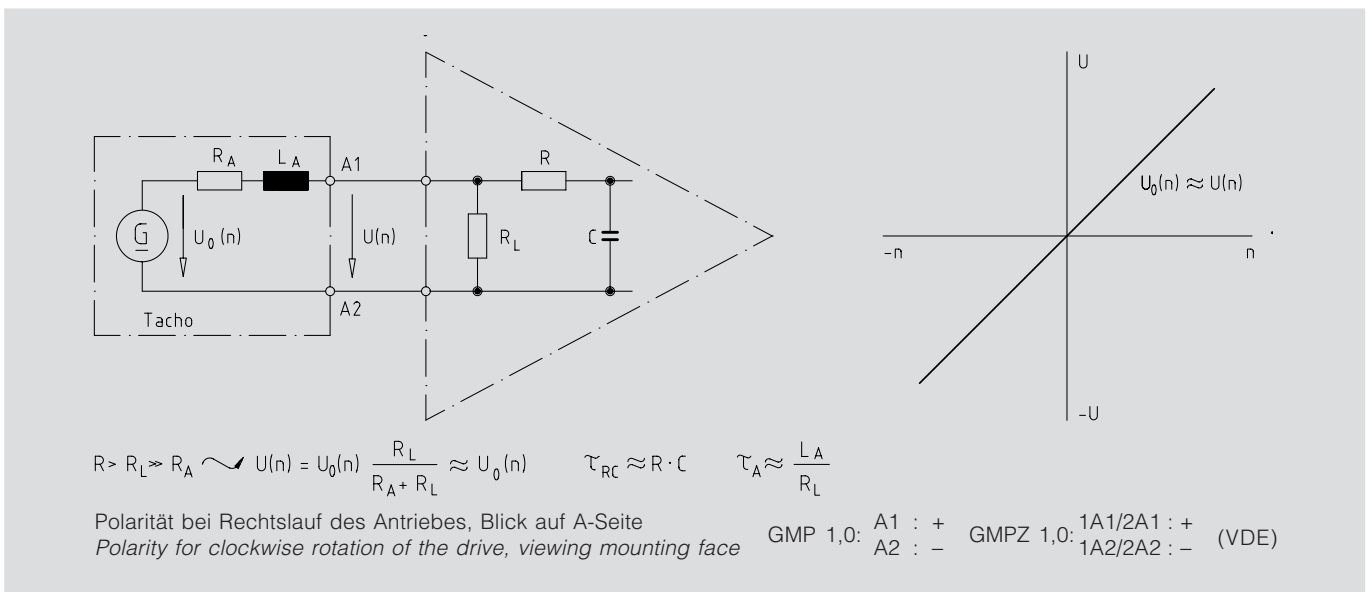

GMP 1,0 • GMPZ 1,0

Umfangreiche Produktfamilie mit vielen elektrischen und mechanischen Varianten.

GMP 1,0 • GMPZ 1,0

Comprehensive product family with multiple electrical and mechanical variants.

GMP 1,0 • GMPZ 1,0

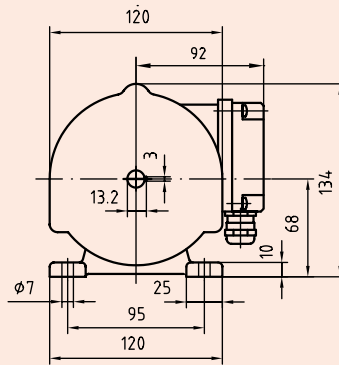
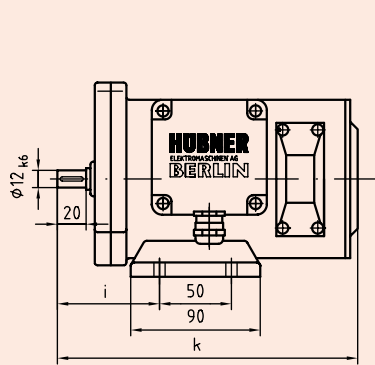

B3 - HM97 M24580

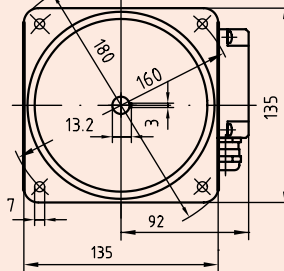
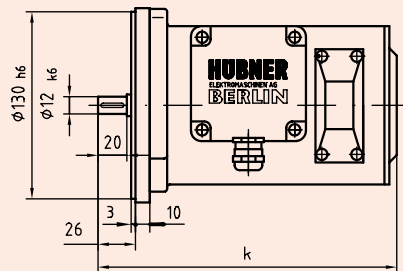

B5 - HM97 M24581

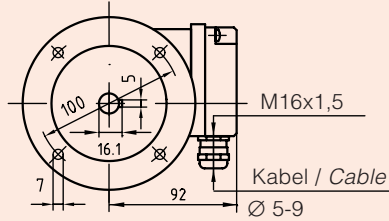
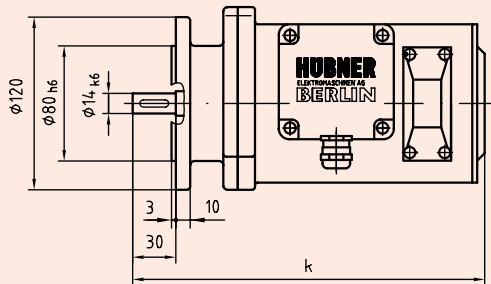

B5n - HM97 M24582

RAL 7021 anthrazit

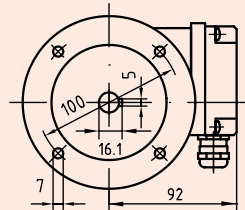
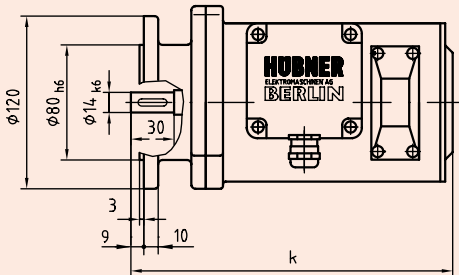

B5s - HM97 M24583

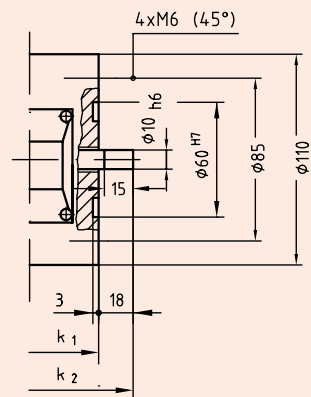

Option ... / B14

Zweites Wellenende und Flansch B14 auf der B-Seite
Rear extension shaft and B14 flange at the B-side

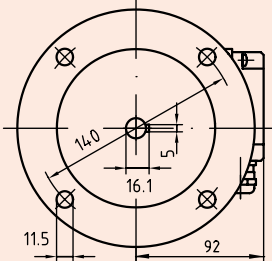
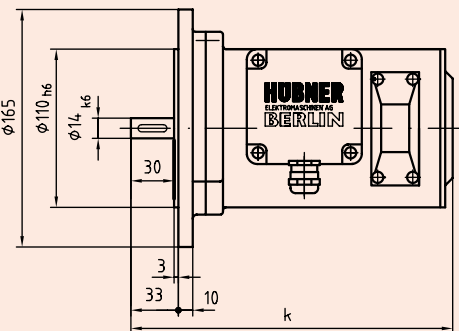

B5k - HM97 M24584

		GMP 1,0	GMPZ 1,0
B3, B5	k	208	275
B3 / B14 B5 / B14	k ₁	199	266
	k ₂	217	284
	i	71	138
B5n	k	245	312
B5n / B14	k ₁	236	303
	k ₂	254	321
B5s, B5k	k	224	291
B5s / B14 B5k / B14	k ₁	215	282
	k ₂	233	300